

### 3-TERMINAL 0.1A POSITIVE VOLTAGE REGULATORS

#### DESCRIPTION

The 78LXX series of fixed voltage monolithic integrated circuit voltage regulators are suitable for applications that required supply up to 100mA.

#### FEATURE

- \*Maximum output current of 100mA
- \*Output voltage of 5V,6V,8V,9V,10V,12V,15V
- \*Thermal overload protection
- \*Short circuit current limiting

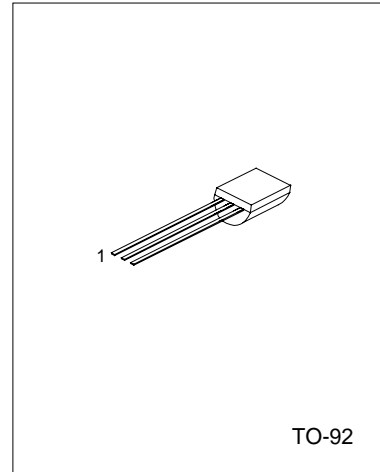

TO-92

1:Output 2:GND; 3:Input

#### BLOCK DIAGRAM

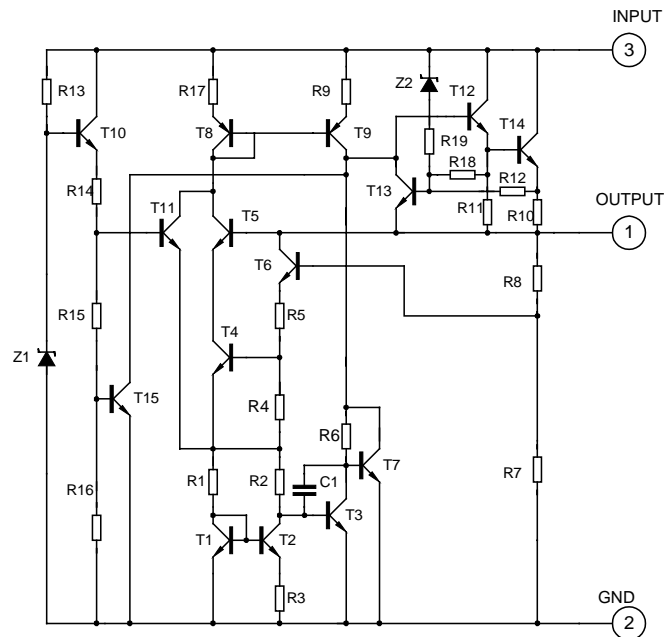

**ABSOLUTE MAXIMUM RATINGS** (Operating temperature range applies unless otherwise specified)

CHARACTERISTICS	SYMBOL	VALUE	UNITS
Input voltage(for $V_o=5,8V$ ) (for $V_o=12,15V$ )	$V_i$	21	V
	$V_i$	35	V
Operating Junction Temperature Range	$T_{OPR}$	-20~+120	°C
Storage Temperature Range	$T_{STG}$	-55~+150	°C

**78L05 ELECTRICAL CHARACTERISTICS**

(VI=10V, Io=40mA, 0&lt;Tj&lt;125°C, C1=0.33μF, Co=0.1μF, unless otherwise specified)(Note 1)

Characteristic	Symbol	Test conditions	MIN	TYP	MAX	UNIT
Output Voltage	$V_o$	$T_j=25^\circ C$	4.8	5.0	5.2	V
		$7V \leq V_i \leq 20V, I_o=1mA \sim 40mA$	4.75		5.25	V
		$7V \leq V_i \leq V_{MAX}, I_o=1mA \sim 70mA$	4.75		5.25	V (note 2)
Load Regulation	$\Delta V_o$	$T_j=25^\circ C, I_o=1mA \sim 100mA$		11	60	mV
		$T_j=25^\circ C, I_o=1mA \sim 40mA$		5.0	30	mV
Line regulation	$\Delta V_o$	$7V \leq V_i \leq 20V, T_j=25^\circ C$		8	150	mV
		$8V \leq V_i \leq 20V, T_j=25^\circ C$		6	100	mV
Quiescent Current	$I_q$			2.0	5.5	mA
Quiescent Current Change	$\Delta I_q$	$8V \leq V_i \leq 20V$			1.5	mA
	$\Delta I_q$	$1mA \leq V_i \leq 40mA$			0.1	mA
Output Noise Voltage	$V_N$	$10Hz \leq f \leq 100kHz$		40		μV
Temperature coefficient of $V_o$	$\Delta V_o / \Delta T$	$I_o=5mA$		-0.65		mV/°C
Ripple Rejection	RR	$8V \leq V_i \leq 20V, f=120Hz, T_j=25^\circ C$	41	80		dB
Dropout Voltage	$V_d$	$T_j=25^\circ C$		1.7		V

**78L06 ELECTRICAL CHARACTERISTICS**

(VI=12V, Io=40mA, 0&lt;Tj&lt;125°C, C1=0.33μF, Co=0.1μF, unless otherwise specified)(Note 1)

Characteristic	Symbol	Test conditions	MIN	TYP	MAX	UNIT
Output Voltage	$V_o$	$T_j=25^\circ C$	5.75	6.0	6.25	V
		$8.5V \leq V_i \leq 20V, I_o=1mA \sim 40mA$	5.7		6.3	V
		$8.5V \leq V_i \leq V_{MAX}, I_o=1mA \sim 70mA$	5.7		6.3	V (note 2)
Load Regulation	$\Delta V_o$	$T_j=25^\circ C, I_o=1mA \sim 100mA$		12.8	80	mV
		$T_j=25^\circ C, I_o=1mA \sim 70mA$		5.8	40	mV
Line regulation	$\Delta V_o$	$8.5V \leq V_i \leq 20V, T_j=25^\circ C$		64	175	mV
		$9V \leq V_i \leq 20V, T_j=25^\circ C$		54	125	mV
Quiescent Current	$I_q$			3.9	6.0	mA
Quiescent Current Change	$\Delta I_q$	$9V \leq V_i \leq 20V$			1.5	mA
	$\Delta I_q$	$1mA \leq V_i \leq 40mA$			0.1	mA
Output Noise Voltage	$V_N$	$10Hz \leq f \leq 100kHz$		49		μV
Temperature coefficient of $V_o$	$\Delta V_o / \Delta T$	$I_o=5mA$		0.75		mV/°C
Ripple Rejection	RR	$10V \leq V_i \leq 20V, f=120Hz, T_j=25^\circ C$	40	46		dB
Dropout Voltage	$V_d$	$T_j=25^\circ C$		1.7		V

**78L08 ELECTRICAL CHARACTERISTICS**

(VI=14V, Io=40mA, 0&lt;Tj&lt;125°C, C1=0.33μF, Co=0.1μF, unless otherwise specified)(Note 1)

Characteristic	Symbol	Test conditions	MIN	TYP	MAX	UNIT
Output Voltage	Vo	Tj=25°C	7.7	8.0	8.3	V
		10.5V≤Vi≤20V, Io=1mA~40mA	7.6		8.4	V
		10.5V≤Vi≤VMAX, Io=1mA~70mA	7.6		8.4	V (note 2)
Load Regulation	ΔVo	Tj=25°C, Io=1mA~100mA		15	80	mV
		Tj=25°C, Io=1mA~70mA		8.0	40	mV
Line regulation	ΔVo	10.5V≤Vi≤20V, Tj=25°C		10	175	mV
		11V≤Vi≤20V, Tj=25°C		8	125	mV
Quiescent Current	Iq			2.0	5.5	mA
Quiescent Current Change	ΔIq	11V≤Vi≤20V			1.5	mA
	ΔIq	1mA≤Vi≤40mA			0.1	mA
Output Noise Voltage	VN	10Hz≤f≤100kHz		49		μV
Temperature coefficient of Vo	ΔVo/ΔT	Io=5mA		0.75		mV/°C
Ripple Rejection	RR	11V≤Vi≤20V, f=120Hz, Tj=25°C	39	70		dB
Dropout Voltage	Vd	Tj=25°C		1.7		V

**78L09 ELECTRICAL CHARACTERISTICS**

(VI=15V, Io=40mA, 0&lt;Tj&lt;125°C, C1=0.33μF, Co=0.1μF, unless otherwise specified)(Note 1)

Characteristic	Symbol	Test conditions	MIN	TYP	MAX	UNIT
Output Voltage	Vo	Tj=25°C	8.64	9.0	9.36	V
		11.5V≤Vi≤21V, Io=1mA~40mA	8.55		9.45	V
		11.5V≤Vi≤VMAX, Io=1mA~70mA	8.55		9.45	V (note 2)
Load Regulation	ΔVo	Tj=25°C, Io=1mA~100mA		20	90	mV
		Tj=25°C, Io=1mA~40mA		10	45	mV
Line regulation	ΔVo	11.5V≤Vi≤21V, Tj=25°C		90	200	mV
		13V≤Vi≤21V, Tj=25°C		100	150	mV
Quiescent Current	Iq			2.0	6.0	mA
Quiescent Current Change	ΔIq	13V≤Vi≤21V			1.5	mA
	ΔIq	1mA≤Vi≤40mA			0.1	mA
Output Noise Voltage	VN	10Hz≤f≤100kHz		49		μV
Temperature coefficient of Vo	ΔVo/ΔT	Io=5mA		0.75		mV/°C
Ripple Rejection	RR	12V≤Vi≤21V, f=120Hz, Tj=25°C	38	44		dB
Dropout Voltage	Vd	Tj=25°C		1.7		V

**78L10 ELECTRICAL CHARACTERISTICS**

(VI=16V, Io=40mA, 0&lt;Tj&lt;125°C, C1=0.33μF, Co=0.1μF, unless otherwise specified)(Note 1)

Characteristic	Symbol	Test conditions	MIN	TYP	MAX	UNIT
Output Voltage	Vo	Tj=25°C	9.6	10.0	10.4	V
		12.5V≤Vi≤21V, Io=1mA~40mA	9.5		10.5	V
		12.5V≤Vi≤VMAX, Io=1mA~70mA	9.5		10.5	V (note 2)
Load Regulation	ΔVo	Tj=25°C, Io=1mA~100mA		20	94	mV
		Tj=25°C, Io=1mA~70mA		10	47	mV
Line regulation	ΔVo	12.5V≤Vi≤21V, Tj=25°C		100	220	mV
		14V≤Vi≤21V, Tj=25°C		200	170	mV
Quiescent Current	Iq		4.2	6.5	mA	
Quiescent Current Change	ΔIq	12.5V≤Vi≤21V			1.5	mA
	ΔIq	1mA≤Vi≤40mA			0.1	mA
Output Noise Voltage	VN	10Hz≤f≤100kHz		74		μV
Temperature coefficient of Vo	ΔVo/ΔT	Io=5mA		0.95		mV/°C
Ripple Rejection	RR	15V≤Vi≤21V, f=120Hz, Tj=25°C	38	43		dB
Dropout Voltage	Vd	Tj=25°C		1.7		V

**78L12 ELECTRICAL CHARACTERISTICS**

(VI=19V, Io=40mA, 0&lt;Tj&lt;125°C, C1=0.33μF, Co=0.1μF, unless otherwise specified)(Note 1)

Characteristic	Symbol	Test conditions	MIN	TYP	MAX	UNIT
Output Voltage	Vo	Tj=25°C	11.5	15	15.6	V
		14.5V≤Vi≤21V, Io=1mA~40mA	11.4		12.6	V
		14.5V≤Vi≤VMAX, Io=1mA~70mA	11.4		12.6	V (note 2)
Load Regulation	ΔVo	Tj=25°C, Io=1mA~100mA		25	150	mV
		Tj=25°C, Io=1mA~40mA		12	75	mV
Line regulation	ΔVo	14.5V≤Vi≤21V, Tj=25°C		25	300	mV
		16V≤Vi≤21V, Tj=25°C		20	250	mV
Quiescent Current	Iq		2.0	6.0	mA	
Quiescent Current Change	ΔIq	16V≤Vi≤21V			1.5	mA
	ΔIq	1mA≤Vi≤40mA			0.1	mA
Output Noise Voltage	VN	10Hz≤f≤100kHz		80		μV
Temperature coefficient of Vo	ΔVo/ΔT	Io=5mA		-1.0		mV/°C
Ripple Rejection	RR	15V≤Vi≤21V, f=120Hz, Tj=25°C	37	65		dB
Dropout Voltage	Vd	Tj=25°C		1.7		V

Note 1: The Maximum steady state usable output current and input voltage are very dependent on the heating sinking and/or lead temperature length of the package. The data above represent pulse test conditions with junction temperatures as indicated at the initiation of test.

Note 2: Power dissipation < 0.75W

## TYPICAL APPLICATION

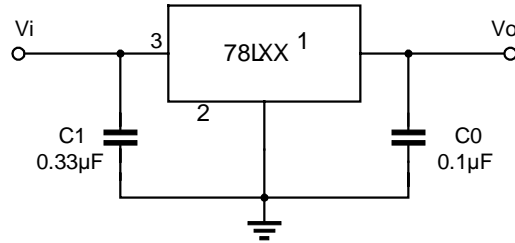

Note 1: To specify an output voltage, substitute voltage value for "XX".

Note 2: Bypass capacitors are recommended for optimum stability and transient response and should be located as close as possible to the regulators.

Note 1: The Maximum steady state usable output current and input voltage are very dependent on the heating sinking and/or lead temperature length of the package. The data above represent pulse test conditions with junction temperatures as indicated at the initiation of test.

Note 2: Power dissipation < 0.75W

## TYPICAL APPLICATION

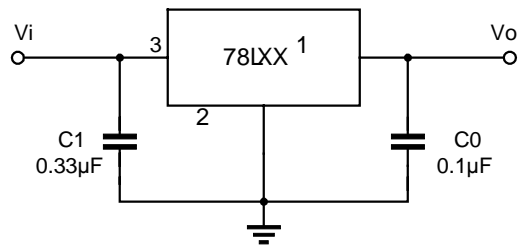

Note 1: To specify an output voltage, substitute voltage value for "XX".

Note 2: Bypass capacitors are recommended for optimum stability and transient response and should be located as close as possible to the regulators.