

OP07C, OP07D PRECISION OPERATIONAL AMPLIFIERS

SLOS099E – OCTOBER 1983 – REVISED MAY 2004

- **Low Noise**
- **No External Components Required**
- **Replace Chopper Amplifiers at a Lower Cost**
- **Wide Input-Voltage Range**
... 0 to ± 14 V Typ
- **Wide Supply-Voltage Range**
... ± 3 V to ± 18 V

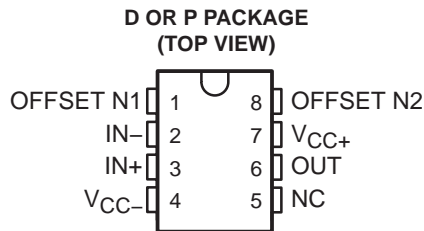

NC – No internal connection

description/ordering information

These devices offer low offset and long-term stability by means of a low-noise, chopperless, bipolar-input-transistor amplifier circuit. For most applications, external components are not required for offset nulling and frequency compensation. The true differential input, with a wide input-voltage range and outstanding common-mode rejection, provides maximum flexibility and performance in high-noise environments and in noninverting applications. Low bias currents and extremely high input impedances are maintained over the entire temperature range. The OP07 is unsurpassed for low-noise, high-accuracy amplification of very-low-level signals.

These devices are characterized for operation from 0°C to 70°C.

ORDERING INFORMATION

T _A	PACKAGE†		ORDERABLE PART NUMBER	TOP-SIDE MARKING
0°C to 70°C	PDIP (P)	Tube of 50	OP07CP	OP07CP
		Tube of 50	OP07DP	OP07DP
	SOIC (D)	Tube of 75	OP07CD	OP07C
		Reel of 2500	OP07CDR	
		Tube of 75	OP07DD	OP07D
		Reel of 2500	OP07DDR	

† Package drawings, standard packing quantities, thermal data, symbolization, and PCB design guidelines are available at www.ti.com/sc/package.

symbol

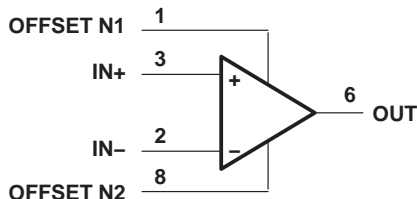

OP07C, OP07D PRECISION OPERATIONAL AMPLIFIERS

SLOS099E – OCTOBER 1983 – REVISED MAY 2004

schematic

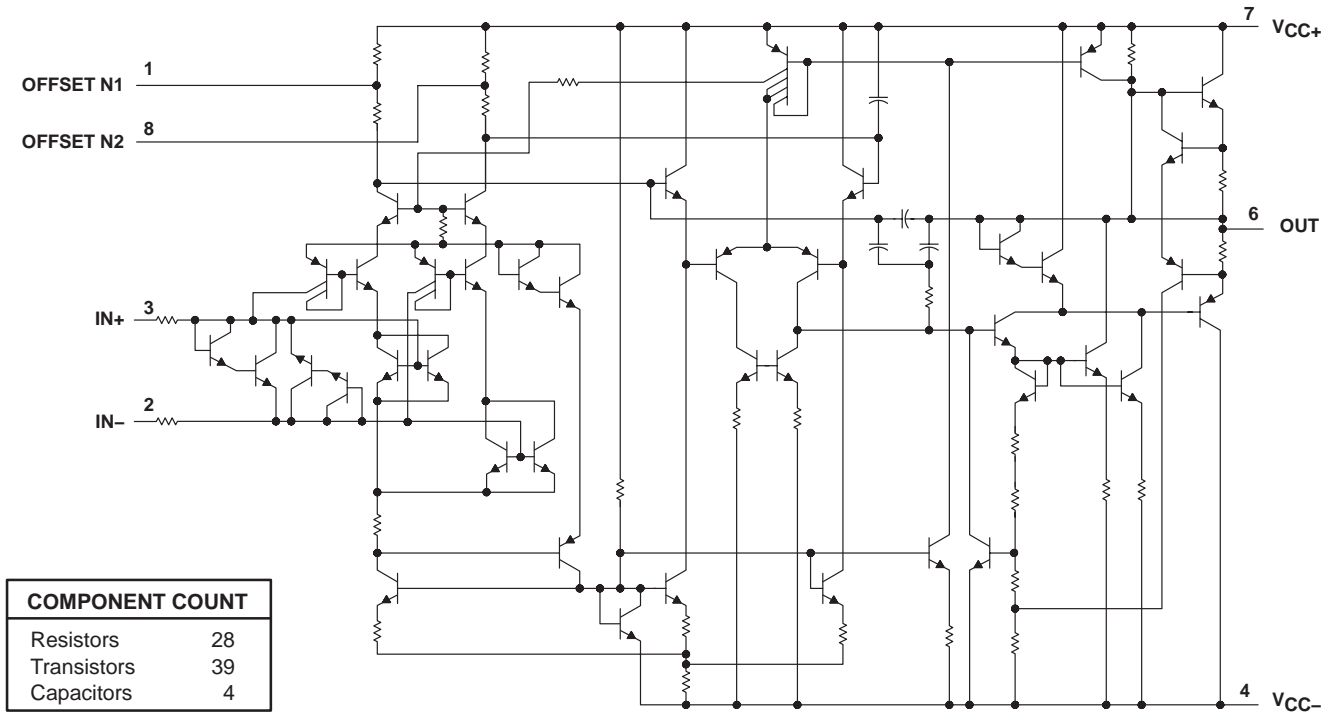

absolute maximum ratings over operating free-air temperature range (unless otherwise noted)†

Supply voltage: V_{CC+} (see Note 1)	22 V
V_{CC-} (see Note 1)	-22 V
Differential input voltage (see Note 2)	± 30 V
Input voltage, V_I (either input, see Note 3)	± 22 V
Duration of output short circuit (see Note 4)	Unlimited
Package thermal impedance, θ_{JA} (see Notes 5 and 6): D package	97°C/W
P package	85°C/W
Operating virtual junction temperature, T_J	150°C
Lead temperature 1,6 mm (1/16 inch) from case for 10 seconds	260°C
Storage temperature range, T_{stg}	-65°C to 150°C

† Stresses beyond those listed under “absolute maximum ratings” may cause permanent damage to the device. These are stress ratings only, and functional operation of the device at these or any other conditions beyond those indicated under “recommended operating conditions” is not implied. Exposure to absolute-maximum-rated conditions for extended periods may affect device reliability.

NOTES: 1. All voltage values, unless otherwise noted, are with respect to the midpoint between V_{CC+} and V_{CC-} .

2. Differential voltages are at IN+ with respect to IN-.

3. The magnitude of the input voltage must never exceed the magnitude of the supply voltage or 15 V, whichever is less.

4. The output may be shorted to ground or to either power supply.

5. Maximum power dissipation is a function of $T_{J(max)}$, θ_{JA} , and T_A . The maximum allowable power dissipation at any allowable ambient temperature is $P_D = (T_{J(max)} - T_A)/\theta_{JA}$. Selecting the maximum of 150°C can affect reliability.

6. The package thermal impedance is calculated in accordance with JESD 51-7.

OP07C, OP07D PRECISION OPERATIONAL AMPLIFIERS

SLOS099E – OCTOBER 1983 – REVISED MAY 2004

recommended operating conditions

			MIN	MAX	UNIT
$V_{CC\pm}$	Supply voltage		± 3	± 18	V
V_{IC}	Common-mode input voltage	$V_{CC\pm} = \pm 15$ V	-13	13	V
T_A	Operating free-air temperature		0	70	°C

OP07C, OP97D PRECISION OPERATIONAL AMPLIFIERS

SLOS099E – OCTOBER 1983 – REVISED MAY 2004

electrical characteristics at specified free-air temperature, $V_{CC\pm} = \pm 15\text{ V}$ (unless otherwise noted)

PARAMETER	TEST CONDITION [†]	T _A	OP07C			OP07D			UNIT
			MIN	TYP	MAX	MIN	TYP	MAX	
V _{IO}	V _O = 0, R _S = 50 Ω	25°C	60	150		60	150	μV	
		0°C to 70°C	85	250		85	250		
α _{VIO}	V _O = 0, R _S = 50 Ω	0°C to 70°C	0.5	1.8		0.7	2.5	μV/°C	
	See Note 6		0.4			0.5		μV/mo	
	R _S = 20 kΩ, See Figure 1	25°C	±4			±4		mV	
I _{IO}		25°C	0.8	6		0.8	6	nA	
		0°C to 70°C	1.6	8		1.6	8		
α _{IIO}		0°C to 70°C	12	50		12	50	pA/°C	
I _{IB}		25°C	±1.8	±7		±2	±12	nA	
		0°C to 70°C	±2.2	±9		±3	±14		
α _{IIB}		0°C to 70°C	18	50		18	50	pA/°C	
V _{ICR}		25°C	±13	±14		±13	±14	V	
		0°C to 70°C	±13	±13.5		±13	±13.5		
V _{OM}	R _L ≥ 10 kΩ		±12	±13		±12	±13	V	
	R _L ≥ 2 kΩ	25°C	±11.5	±12.8		±11.5	±12.8		
	R _L ≥ 1 kΩ		±12			±12			
	R _L ≥ 2 kΩ	0°C to 70°C	±11	±12.6		±11	±12.6		
A _{VD}	V _{CC±} = ±3 V, V _O = ±0.5 V, R _L ≥ 500 kΩ	25°C	100	400		400		V/mV	
		25°C	120	400		120	400		
	V _O = ±10 V, R _L = 2 kΩ	0°C to 70°C	100	400		100	400		
B ₁		25°C	0.4	0.6		0.4	0.6	MHz	
r _i		25°C	8	33		7	31	MΩ	
CMRR		25°C	100	120		94	110	dB	
	V _{IC} = ±13 V, R _S = 50 Ω	0°C to 70°C	97	120		94	106		
kSVS	V _{CC±} = ±3 V to ±18 V, R _S = 50 Ω	25°C	7	32		7	32	μV/V	
		0°C to 70°C	10	51		10	51		
P _D	V _O = 0, No load		80	150		80	150	mW	
	V _{CC±} = ±3 V, V _O = 0, No load	25°C	4	8		4	8		

† All characteristics are measured under open-loop conditions, with zero common-mode input voltage, unless otherwise noted.

NOTE 7: Since long-term drift cannot be measured on the individual devices prior to shipment, this specification is not intended to be a warranty. It is an engineering estimate of the averaged trend line of drift versus time over extended periods after the first 30 days of operation.

operating characteristics, $V_{CC\pm} = \pm 15\text{ V}$, $T_A = 25^\circ\text{C}$

PARAMETER	TEST CONDITION [†]	OP07C	OP07D	UNIT
		TYP	TYP	
V_n Equivalent input noise voltage	$f = 10\text{ Hz}$	10.5	10.5	$\text{nV}/\sqrt{\text{Hz}}$
	$f = 100\text{ Hz}$	10.2	10.3	
	$f = 1\text{ kHz}$	9.8	9.8	
$V_{N(PP)}$ Peak-to-peak equivalent input noise voltage	$f = 0.1\text{ Hz to }10\text{ Hz}$	0.38	0.38	μV
I_n Equivalent input noise current	$f = 10\text{ Hz}$	0.35	0.35	$\text{pA}/\sqrt{\text{Hz}}$
	$f = 100\text{ Hz}$	0.15	0.15	
	$f = 1\text{ kHz}$	0.13	0.13	
$I_{N(PP)}$ Peak-to-peak equivalent input noise current	$f = 0.1\text{ Hz to }10\text{ Hz}$	15	15	pA
SR Slew rate	$R_L \geq 2\text{ k}\Omega$	0.3	0.3	$\text{V}/\mu\text{s}$

[†] All characteristics are measured under open-loop conditions, with zero common-mode input voltage, unless otherwise noted.

APPLICATION INFORMATION

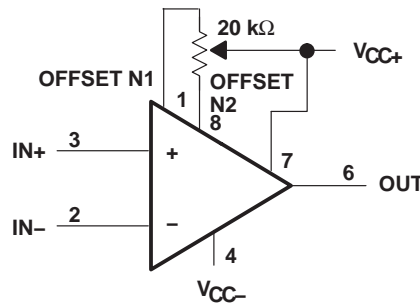
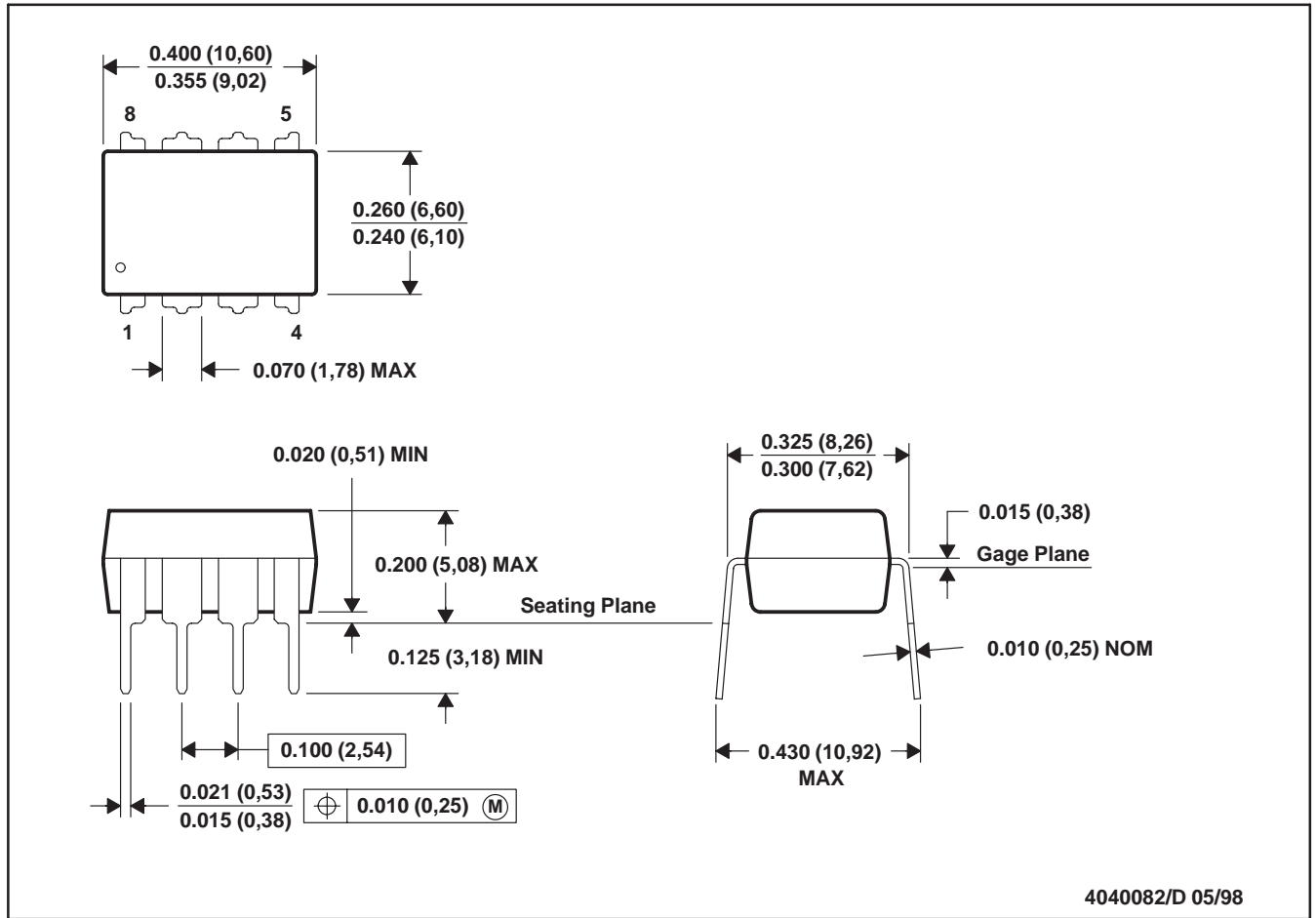

Figure 1. Input Offset-Voltage Null Circuit

P (R-PDIP-T8)

PLASTIC DUAL-IN-LINE



- NOTES: A. All linear dimensions are in inches (millimeters).
 B. This drawing is subject to change without notice.
 C. Falls within JEDEC MS-001

D (R-PDSO-G8)

PLASTIC SMALL-OUTLINE PACKAGE

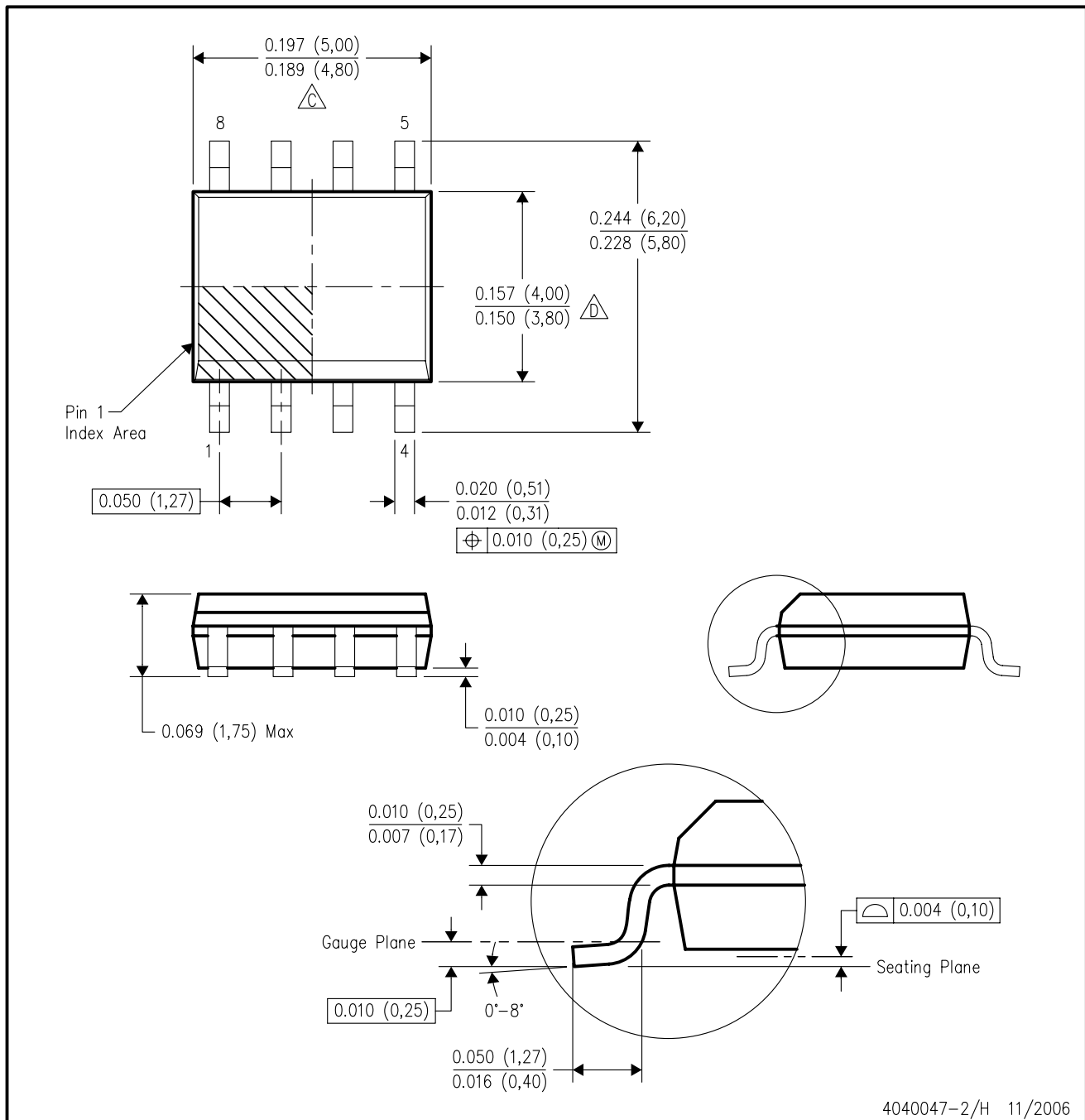

MECHANICAL DATA

PS (R-PDSO-G8)

PLASTIC SMALL-OUTLINE PACKAGE



- NOTES:
- A. All linear dimensions are in millimeters.
 - B. This drawing is subject to change without notice.
 - C. Body dimensions do not include mold flash or protrusion, not to exceed 0,15.